



Full cone
nozzles

Full cone nozzles

- Absorption
- Chemical process engineering
- Chlorine precipitation
- Cleaning
- Cooling
- Desuperheating
- Dust control
- Fire protection
- Foam control
- Gas treatment
- Spraying onto mats in air washers
- Spraying over packings
- Surface spraying
- Water treatment
- and many others...

H₂

H₁

G

B

D

CA-
EG

G

L₂

L₁

Hex



Full cone nozzles

Axial-flow full cone nozzles

Lechler full cone nozzles have an extraordinarily uniform liquid distribution over the whole circular impact area. The high precision of distribution is achieved by orienting the liquid inlet to the centre of the swirl chamber of the nozzle. The optimized x-style swirl insert ensures a high operating safety due to its large free cross-sections.

Axial-flow full cone nozzles are available with different spray angles and in many flow rates. Therefore, matching to specific service conditions is possible without any difficulties.

- Extremely uniform liquid distribution
- Wide flow rate range
- Large number of available spray angles

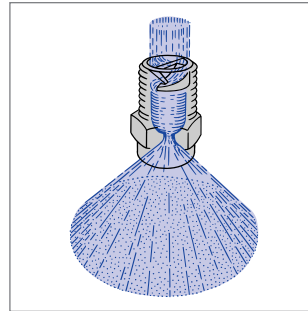

Special design for fire fighting: Deflector-plate nozzle

Tangential flow full cone nozzles

Tangential-flow full cone nozzles are, for instance, particularly suited for closed-circuit spraying of liquids with a high quota of solid matter, or for fire fighting applications. The atomizing fluid is tangentially supplied to a swirl chamber, where it is put into rotation. Tangential-flow full cone nozzles are free of swirl inserts. Hence, they are not at all prone to clogging. The full cone spray is obtained with the aid of specially arranged grooves, milled into the nozzle bottom, which cause an adequate part of the rotating liquid flow to diverge to the center of the

swirl chamber. Thereby, an extremely uniform area distribution of the sprayed liquid is achieved.

- Reliable in service
- Non-clogging
- Stable spray angles, unaffected by transient pressures

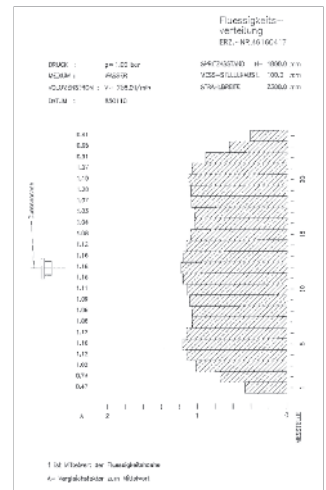
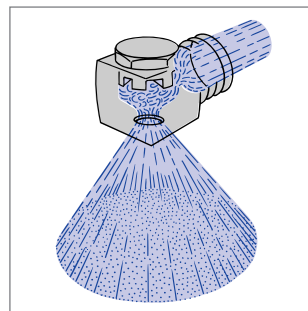

Typical liquid distribution chart

Cluster Head Nozzles

Lechler cluster head nozzles achieve a very large surface of the sprayed liquid by adding various finely atomizing single nozzles. Whenever a fine fog-like full cone atomization with relatively large flow rates is necessary, e.g. gas exchange processes, steam cooling or dust suppression, Lechler cluster head nozzles have decisive advantages: overlapping hollow cones form a fine full cone atomization with an increased droplet surface area. These very fine droplets cannot be achieved by a

single-orifice spray nozzle of the same flow rate size.

The increased droplet surface area of the atomized liquid provides great efficiency in gas treatment and cooling applications.

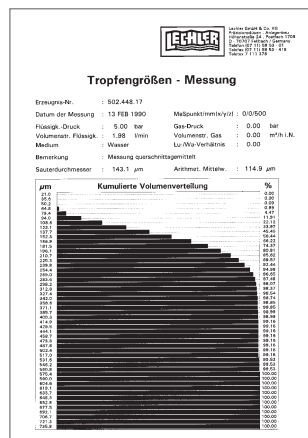



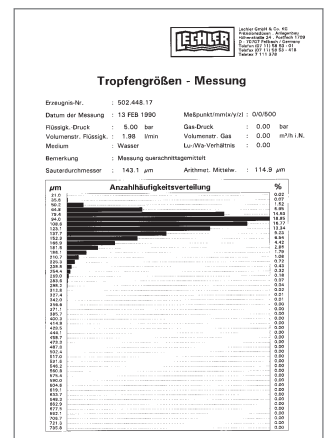



Cumulated volume distribution



Number distribution









Full cone nozzles

Axial-flow full cone nozzles	Series		\dot{V} [l/min] at p = 2 bar	Connection	Application/ Design	Page
	460	45° 60° 90° 120°	0,63 – 63,00	1/8 BSPT 1/4 BSPT 3/8 BSPT 1/2 BSPT 3/4 BSPP 1 BSPP	Cleaning and washing process, cooling of gaseous fluids and solids, surface spraying, spraying onto mats in air washers, improving on chemical reactions. Large free cross-sections, due to optimized x-style swirl insert.	3.5
	405	60° 90° 120°	100,00 – 315,00	1 1/4 BSPP 1 1/2 BSPP 2 BSPP	Surface spraying, spraying over packings, cleaning and washing process, chemical process engineering, cooling of gaseous fluids and solids, water treatment. Uniform full cone spray.	3.7
	403	90° 120°	400,00 – 1250,00	2 1/2 BSPP 3 BSPP 3 1/2 BSPP 4 BSPP	Surface spraying, spraying over packings, cleaning and washing process, chemical process engineering, cooling of gaseous fluids and solids, water treatment. Uniform full cone spray.	3.8
	468	60° 90° 120°	1,00 – 12,50	Assembly with 3/8" retaining nut	Surface spraying, spraying over packings, chemical process engineering, cleaning and washing processes, cooling of gaseous fluids and solids. Uniform full cone spray.	3.9
Tangential-flow full cone nozzles	Series		\dot{V} [l/min] at p = 2 bar	Connection	Application/ Design	Page
	422	60° 90° 120°	1,00 – 63,00	1/4 BSPT 3/8 BSPT 1/2 BSPT 3/4 BSPT	Cleaning and washing process, cooling of gaseous fluids and solids, surface spraying, spraying onto mats in air washers, improving on chemical reactions, continuous casting. Without swirl inserts, non-clogging.	3.10 3.11



Full cone nozzles

Tangential-flow full cone nozzles		Series		\dot{V} [l/min] at $p = 2$ bar	Connection	Application/ Design	Page
	422 Bayonet quick-release system	60° 90° 120°		1,00 – 4,00	Assembly with bayonet quick-release system	Cleaning problems, cooling process, foam control. Quick and safe assembly, without tools. Space-saving installation.	3.12
Cluster head nozzles		Series		\dot{V} [l/min] at $p = 2$ bar	Connection	Application/ Design	Page
	502 503	70° 130°		1,25 – 60,00	1/2 BSPP 3/4 BSPP	Cooling of gaseous and solid material, desuperheating, chlorine precipitation, absorption as well as for improvement of chemical reaction by enlarging the contact area. Fine full cone atomization with the aid of several hollow cones spraying into one another.	3.13
	520 523	130°		8,50 – 90,00	1 BSPP	Fire fighting, cooling of gaseous and solid material, chlorine precipitation. Extremely fine full cone atomization with the aid of several hollow cones spraying into one another.	On request. For further informations please refer to our brochure „Lechler nozzles for fire fighting“
Deflector-plate nozzle		Series		\dot{V} [l/min] at $p = 2$ bar	Connection	Application/ Design	Page
	525	180°		7,10 – 80,00	1/2 BSPP	Fire fighting and broadcast spraying. Non-clogging nozzle without swirl inserts. VDS approved.	3.14



Axial-flow full cone nozzles

Series 460 / 461



**Very uniform spray pattern.
Large free cross-sections,
due to optimized
x-style swirl insert.**

Applications:

Cleaning and washing process, cooling of gaseous fluids and solids, surface spraying, spraying onto mats in air washers, improving of chemical reactions. Large free cross-sections, due to optimized x-style swirl insert.

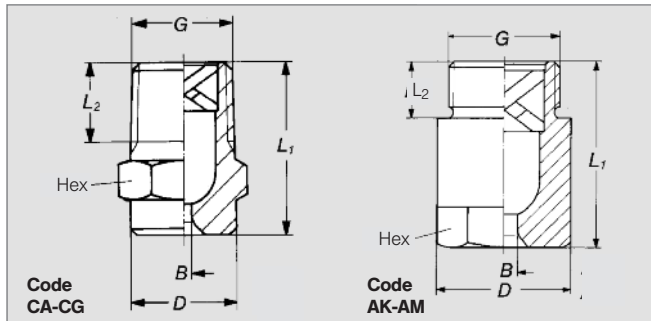

Code	G	Dimensions [mm]			Hex	Weight Brass
		L ₁	L ₂	D		
CA	1/8 BSPT	18,0	6,5	10,0	11	15 g
CC	1/4 BSPT	22,0	10,0	13,0	14	17 g
CE	3/8 BSPT	24,5	10,0	16,0	17	30 g
CE	1/8 BSPT	30,0	10,0	16,0	17	50 g
CG	1/2 BSPT	32,5	13,0	21,0	22	67 g
CG	1/2 BSPT	43,5	13,0	21,0	22	85 g
AK	3/4 BSPP	42,0	15,0	32,0	27	170 g
AK	3/4 BSPP	50,0	15,0	32,0	27	200 g
AM	1 BSPP	56,0	17,0	40,0	36	360 g

Subject to technical modifications.

Spray angle	Ordering no.										B Ø [mm]	E Ø [mm]	Ḃ [l/min]							Spray diameter D at p=2 bar	
	Type	Material-no.			Code								p [bar]								
		17	30	5E	1/8 BSPT	1/4 BSPT	3/8 BSPT	1/2 BSPT	3/4 BSPP	1 BSPP			[US gal/min] at 40 psi								
		1.4571/316SS	Brass	PVDF									0,5	1,0	2,0	3,0	5,0	10,0			
45°	460.403	○	○	-	CA	-	-	-	-	-	1,20	0,85	0,57	0,76	1,00	0,30	1,18	1,44	1,90	160	400
	460.523	○	○	-	CA	-	-	-	-	-	1,50	1,35	1,15	1,52	2,00	0,60	2,35	2,89	3,81	160	400
	460.603	○	○	-	-	CC	CE	-	-	-	1,90	1,80	1,81	2,39	3,15	0,95	3,70	4,54	6,00	160	400
	460.643	○	○	-	-	CC	CE	-	-	-	2,15	2,00	2,30	3,03	4,00	1,20	4,70	5,77	7,61	160	400
	460.683	-	○	-	-	CC	CE	-	-	-	2,40	2,00	2,87	3,79	5,00	1,50	5,88	7,21	9,52	160	400
	460.703	-	○	-	-	-	CE	-	-	-	2,55	2,20	3,22	4,24	5,60	1,68	6,59	8,08	10,66	160	400
	460.723	○	○	-	-	-	CE	CG	-	-	2,70	2,35	3,62	4,77	6,30	1,89	7,41	9,09	11,99	160	400
	460.783	-	○	-	-	-	-	CG	-	-	3,20	3,20	5,17	6,82	9,00	2,70	10,58	12,98	17,12	160	400
	460.843	-	○	-	-	-	-	CG	-	-	3,80	3,70	7,18	9,47	12,50	3,75	14,70	18,03	23,80	160	400
60°	460.404	○	○	-	CA	-	-	-	-	-	1,20	0,85	0,57	0,76	1,00	0,30	1,18	1,44	1,90	220	560
	460.444	○	-	-	CA	-	-	-	-	-	1,30	1,05	0,72	0,95	1,25	0,38	1,47	1,80	2,38	220	560
	460.484	○	○	-	CA	-	-	-	-	-	1,45	1,15	0,92	1,21	1,60	0,48	1,88	2,31	3,05	220	560
	460.524	○	○	-	CA	-	-	-	-	-	1,60	1,20	1,15	1,52	2,00	0,60	2,35	2,89	3,81	220	560
	460.604	○	○	-	CA	-	CE	-	-	-	2,05	1,40	1,81	2,39	3,15	0,95	3,70	4,54	6,00	220	560
	460.644	○	○	-	-	CC	CE*	-	-	-	2,40	1,90	2,30	3,03	4,00	1,20	4,70	5,77	7,61	220	560
	460.684	○	○	-	-	CC	CE	-	-	-	2,60	2,00	2,87	3,79	5,00	1,50	5,88	7,21	9,52	220	560
	460.724	○	○	-	-	CC	CE	-	-	-	2,90	2,00	3,62	4,77	6,30	1,89	7,41	9,09	11,99	220	560
	460.764	○	○	-	-	-	CE	-	-	-	3,25	2,85	4,59	6,06	8,00	2,40	9,41	11,54	15,22	220	560
	460.804	○	○	-	-	-	CE	-	-	-	3,60	2,95	5,74	7,58	10,00	3,00	11,76	14,43	19,04	220	560
	460.844	○	○	-	-	-	-	CG	-	-	4,00	3,30	7,18	9,47	12,50	3,75	14,70	18,03	23,80	220	560
	460.884	○	○	-	-	-	-	CG	-	-	4,50	3,70	9,19	12,13	16,00	4,80	18,82	23,08	30,46	220	560
	460.924	○	○	-	-	-	-	-	AK	-	5,20	4,50	11,49	15,16	20,00	6,01	23,52	28,85	38,07	220	560
	460.964	○	○	-	-	-	-	-	AK	-	5,80	4,90	14,36	18,95	25,00	7,51	29,40	36,07	47,59	220	560
	461.044	○	○	-	-	-	-	-	-	AM	7,20	5,40	22,97	30,31	40,00	12,01	47,04	57,71	76,15	220	560
	461.084	○	○	-	-	-	-	-	-	AM	8,60	6,50	28,72	37,89	50,00	15,02	58,80	72,14	95,18	220	560

B = bore diameter · E = narrow free cross section

*Only in material 30

Continued on next page.

Conversion formula for the above series: $\dot{V}_2 = \dot{V}_1 * \left(\frac{P_2}{P_1}\right)^{0,4}$ (≤ 10 bar)





Axial-flow full cone nozzles

Series 460 / 461



Spray angle	Ordering no.										B Ø [mm]	E Ø [mm]	V̇ [l/min]							Spray diameter D at p=2 bar	
	Type	Material-no.			Code								p [bar]							H = 200 mm	H = 500 mm
		17 1.4571/316SS	30 Brass	5E PVDF	1/8 BSPT	1/4 BSPT	3/8 BSPT	1/2 BSPT	3/4 BSPP	1 BSPP			p [bar]								
													0,5	1,0	2,0	[US gal./min] at 40 psi	3,0	5,0	10,0		
90°	460.326	-	-	○	CA	-	-	-	-	-	0,80	0,55	0,23	0,30	0,40	0,12	0,47	0,58	0,76	380	860
	460.406	○	○	○	CA	-	-	-	-	-	1,20	0,85	0,57	0,76	1,00	0,30	1,18	1,44	1,90	380	860
	460.446	-	-	-	CA	-	-	-	-	-	1,30	1,00	0,72	0,95	1,25	0,38	1,47	1,80	2,38	380	860
	460.486	○	○	○	CA	-	-	-	-	-	1,45	1,20	0,92	1,21	1,60	0,48	1,88	2,31	3,05	380	860
	460.526	○	○	○	CA	-	-	-	-	-	1,65	1,30	1,15	1,52	2,00	0,60	2,35	2,89	3,81	380	860
	460.566	○	○	-	CA	-	-	-	-	-	1,85	1,30	1,44	1,89	2,50	0,75	2,94	3,61	4,76	380	860
	460.606	○	○	○	CA	-	CE	-	-	-	2,05	1,45	1,81	2,39	3,15	0,95	3,70	4,54	6,00	380	860
	460.646	○	○	○	-	CC	CE	-	-	-	2,30	1,80	2,30	3,03	4,00	1,20	4,70	5,77	7,61	390	960
	460.686	○	○	-	-	CC	CE	-	-	-	2,60	1,80	2,87	3,79	5,00	1,50	5,88	7,21	9,52	390	960
	460.726	○	○	○*	-	CC	CE	-	-	-	2,95	2,00	3,62	4,77	6,30	1,89	7,41	9,09	11,99	390	960
	460.746	-	-	○	-	-	CE	-	-	-	3,30	1,90	4,08	5,38	7,10	2,13	8,35	10,24	13,52	390	960
	460.766	○	○	○	-	-	CE	-	-	-	3,30	2,40	4,59	6,06	8,00	2,40	9,41	11,54	15,22	390	960
	460.806	○	○	○	-	-	CE	-	-	-	3,70	2,70	5,74	7,58	10,00	3,00	11,76	14,43	19,04	390	960
	460.846	○	○	○	-	-	CE	-	-	-	4,05	3,20	7,18	9,47	12,50	3,75	14,70	18,03	23,80	390	960
	460.886	○	○	○	-	-	-	CG	-	-	4,70	3,10	9,19	12,13	16,00	4,80	18,82	23,08	30,46	390	960
	460.926	○	○	-	-	-	-	CG	-	-	5,20	3,80	11,49	15,16	20,00	6,01	23,52	28,85	38,07	390	960
	460.966	○	○	○	-	-	-	CG	AK	-	5,80	3,80	14,36	18,95	25,00	7,51	29,40	36,07	47,59	390	960
	461.006	○	-	-	-	-	-	CG	AK	-	6,40	3,80	18,09	23,87	31,50	9,46	37,05	45,45	59,97	390	960
	461.046	○	○	⊗	-	-	-	-	AK	-	7,20	5,30	22,97	30,31	40,00	12,01	47,04	57,71	76,15	390	960
	461.086	○***	-	-	-	-	-	-	-	AM	8,20	5,30	28,72	37,89	50,00	15,02	58,80	72,14	95,18	390	960
461.126	○	○	-	-	-	-	-	-	AM	9,30	6,50	36,18	47,75	63,00	18,92	74,09	90,89	119,93	390	960	
461.146	○	-	○	-	-	-	-	-	AM	9,90	6,70	40,78	53,81	71,00	21,32	83,50	102,43	135,16	390	960	
120°	460.368	○	○	-	CA	-	-	-	-	0,95	0,70	0,36	0,48	0,63	0,19	0,74	0,91	1,20	680	1220	
	460.408	○	○	○	CA	-	-	-	-	1,20	0,85	0,57	0,76	1,00	0,30	1,18	1,44	1,90	680	1220	
	460.448	○	○	-	CA	-	-	-	-	1,30	0,90	0,72	0,95	1,25	0,38	1,47	1,80	2,38	680	1220	
	460.488	○	○	○	CA	-	-	-	-	1,50	1,00	0,92	1,21	1,60	0,48	1,88	2,31	3,05	680	1220	
	460.528	○	○	○	CA	-	-	-	-	1,65	1,20	1,15	1,52	2,00	0,60	2,35	2,89	3,81	680	1220	
	460.568	○	○	-	CA	-	-	-	-	1,90	1,35	1,44	1,89	2,50	0,75	2,94	3,61	4,76	680	1220	
	460.608	○	○	○	CA	-	-	-	-	2,10	1,40	1,81	2,39	3,15	0,95	3,70	4,54	6,00	680	1220	
	460.648	○	○	○	-	CC	CE	-	-	-	2,45	1,60	2,30	3,03	4,00	1,20	4,70	5,77	7,61	680	1330
	460.688	○	○	-	-	CC	CE	-	-	-	2,75	1,80	2,87	3,79	5,00	1,50	5,88	7,21	9,52	680	1330
	460.728	○	○	○*	-	CC	CE	-	-	-	3,10	1,90	3,62	4,77	6,30	1,89	7,41	9,09	11,99	680	1330
	460.748	-	-	○	-	-	CE	-	-	-	3,30	1,90	4,08	5,38	7,10	2,13	8,35	10,24	13,52	680	1330
	460.768	○	○	○	-	-	CE	-	-	-	3,50	1,90	4,59	6,44	8,00	2,40	9,41	11,54	15,22	680	1330
	460.808	○	○	○	-	-	CE	-	-	-	3,80	2,40	5,74	7,58	10,00	3,00	11,76	14,43	19,04	680	1330
	460.848	○	○	○	-	-	CE	-	-	-	4,20	2,70	7,18	9,47	12,50	3,75	14,70	18,03	23,80	680	1330
	460.888	○**	○	○	-	-	CE	CG	-	-	4,60	3,10	9,19	12,13	16,00	4,80	18,82	23,08	30,46	680	1330
	460.928	○	○	-	-	-	-	CG	-	-	5,30	3,30	11,49	15,16	20,00	6,01	23,52	28,85	38,07	680	1330
	460.968	○	○	○**	-	-	-	CG	AK	-	5,90	4,10	14,36	18,95	25,00	7,51	29,40	36,07	47,59	680	1330
	461.048	○	○	⊗	-	-	-	-	AK	-	7,60	4,90	22,97	30,31	40,00	12,01	47,04	57,71	76,15	680	1330
	461.128	○	○	-	-	-	-	-	-	AM	9,60	6,60	36,18	47,75	63,00	18,92	74,09	90,89	119,93	680	1330
	461.148	○	-	○	-	-	-	-	-	AM	10,00	6,60	40,78	53,81	71,00	21,32	83,50	102,43	135,16	680	1330

B = bore diameter · E = narrowest free cross section
 ⊗ Material PP (Material no. 53), connection 3/4 BSPT (Code CK)
 * Only available with code CE
 ** Only available with code CG
 *** Only available with code AM

The folded page at the end of the catalogue will give you a survey on the various assembly possibilities. For complete assembly accessories, please refer to „Accessories“.

Example Type + Material no. + Code = Ordering no.
for ordering: 460.326 + 5E + CA = 460.326.5E.CA



Conversion formula for the above series: $\dot{V}_2 = \dot{V}_1 \cdot \left(\frac{p_2}{p_1}\right)^{0,4}$ (≤ 10 bar)



Axial-flow full cone nozzles

Series 405



Very uniform spray pattern.

Applications:

Surface spraying, spraying over packings, cleaning and washing process, chemical process engineering, cooling of gaseous fluids and solids, water treatment. Large free cross-sections, due to optimized x-style swirl insert.

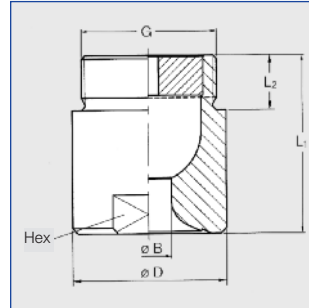

Dimensions [mm]				
BSPP	L ₁	L ₂	D	Hex
1 1/4"	50	19	49	41
1 1/2"	60	19	59	50
2"	78	24	68	60

Spray angle	Ordering no.		Code			B Ø [mm]	E Ø [mm]	ṽ [l/min]						Spray diameter D at p=2 bar		
	Type	Mat.-no.		1 1/4 BSPP	1 1/2 BSPP			2 BSPP	p [bar]						H =	
		17	30						0,3	0,5	1,0	2,0	3,0	5,0	0,5 m	1 m
60°	405. 204	○	○	AP	-	-	11,20	5,80	47	57	76	100	118	144	560	1040
	405. 284	○	○	-	AR	-	14,30	7,00	75	92	121	160	188	231	580	1080
	405. 324	○	○	-	-	AV	16,40	7,50	94	115	152	200	235	289	580	1080
	405. 364	○	○	-	-	AV	18,40	8,50	117	144	189	250	294	361	580	1080
	405. 404	○	○	-	-	AV	20,00	7,00	147	181	239	315	370	454	580	1100
90°	405. 206	○	○	AP	-	-	12,00	5,00	47	57	76	100	118	144	780	1450
	405. 286	○	○	-	AR	-	15,20	6,20	75	92	121	160	188	231	800	1550
	405. 326	○	○	-	-	AV	17,20	7,70	94	115	152	200	235	289	850	1600
	405. 366	○	○	-	-	AV	19,50	8,70	117	144	189	250	294	361	850	1600
	405. 406	○	○	-	-	AV	22,00	9,50	147	181	239	315	370	454	850	1600
120°	405. 208	○	○	AP	-	-	12,70	5,00	47	57	76	100	118	144	1450	2600
	405. 288	○	○	-	AR	-	16,00	6,60	75	92	121	160	188	231	1500	2700
	405. 328	○	○	-	-	AV	17,80	7,90	94	115	152	200	235	289	1500	2800
	405. 368	○	○	-	-	AV	20,10	8,80	117	144	189	250	294	361	1500	2800
	405. 408	○	○	-	-	AV	22,40	9,10	147	181	239	315	370	454	1500	2800

B = bore diameter · E = narrowest free cross section

Example Type + Material no. + Code = Ordering no.
for ordering: 405. 204 + 17 + AP = 405. 204. 17. AP

The folded page at the end of the catalogue will give you a survey on the various assembly possibilities. For complete assembly accessories, please refer to „Accessories“.

Conversion formula for the above series: $\dot{V}_2 = \dot{V}_1 * \left(\frac{p_2}{p_1}\right)^{0,4}$
(≤ 10 bar)





Axial-flow full cone nozzles

Series 403



Very uniform spray pattern.

Applications:
Surface spraying, spraying over packings, chemical process engineering, cooling of gaseous fluids and solids.

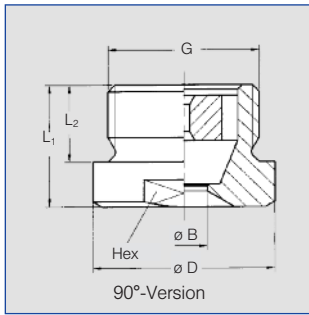
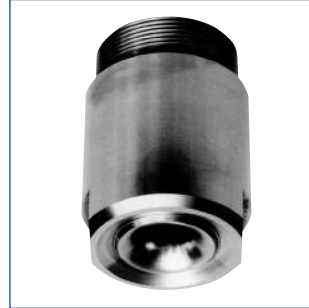
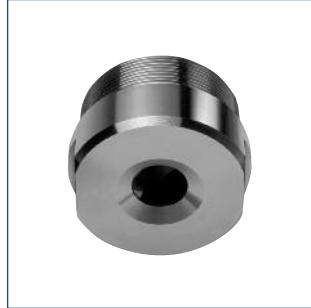

90°-version

Type	BSPP	Dimensions [mm]			
		L ₁	L ₂	D	Hex
403.446/403.486	2 1/2"	52	27	83	75
403.526	3"	60	30	98	85
403.606	3 1/2"	70	32	118	105

120°-version

Type	BSPP	Dimensions [mm]			
		L ₁	L ₂	D	Hex
403.448/403.488	2 1/2"	124	27	83	75
403.528	3"	153	30	98	85
403.568/403.608	3 1/2"	156	32	118	105
403.628	4"	165	36	128	110

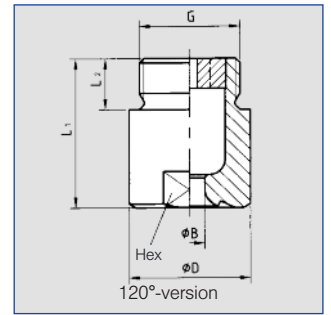

Spray angle	Ordering no..		B ∅ [mm]	E ∅ [mm]	ṽ [l/min]							Spray diameter D at p=2 bar	
	Type	Mat.-no.			p [bar]							H = 0,5 m	H = 1 m
					0,3	0,5	1,0	2,0	3,0	5,0	7,0		
90°	403.446	- ○	25,00	12,00	187	230	303	400	470	577	660	900	1700
	403.486	- ○	29,50	12,00	234	287	379	500	588	721	825	900	1700
	403.526	- ○	32,00	13,80	295	362	477	630	741	909	1040	900	1700
	403.606	- ○	40,00	15,00	468	574	758	1000	1176	1443	1651	980	1750
120°	403.448	○ ○	25,50	10,00	187	230	303	400	470	577	660	1500	2850
	403.488	○ ○	29,50	11,00	234	287	379	500	588	721	825	1500	2850
	403.528	- ○	32,00	15,00	295	362	477	630	741	909	1040	1500	2850
	403.568	○ ○	38,00	12,00	375	459	606	800	941	1154	1320	1500	2850
	403.608	- ○	42,00	12,00	469	574	759	1000	1176	1443	1651	1500	2850
	403.628	- ○	45,00	15,00	585	718	947	1250	1470	1903	2063	1600	2900

B = bore diameter · E = narrowest free cross section

Example for ordering:	Type	+	Material no.	=	Ordering no.
	403.446	+	17	=	403.446.17

The folded page at the end of the catalogue will give you a survey on the various assembly possibilities. For complete assembly accessories, please refer to „Accessories“.



Axial-flow full cone nozzles for retaining nut

Series 468



Full cone nozzle for assembly with retaining nut. Uni-form full cone spray.

Applications:

Surface spraying, spraying over packings, chemical process engineering, cleaning and washing processes, cooling of gaseous fluids and solids.

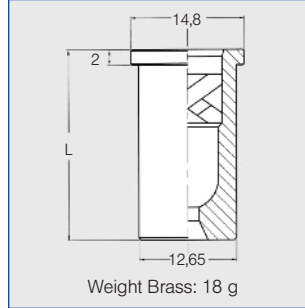

Spray angle	Ordering no.				B Ø [mm]	E Ø [mm]	V̇ [l/min]							L [mm]	Spray diameter D at p = 2 bar	
	Type	Mat.-no.					p [bar]									
		17 1.4571/316SS	30 Brass	5E PVDF			0,5	1,0	2,0	[US gal./min] at 40 psi	3,0	5,0	10,0			
60°	468. 644	-	-	○	2,40	1,90	2,30	3,03	4,00	1,20	4,70	5,77	7,61	24,5	220	560
	468. 724	○	○	-	2,90	2,00	3,62	4,77	6,30	1,89	7,41	9,09	11,99	24,5	220	560
90°	468. 526	○	○	○	1,65	1,30	1,15	1,52	2,00	0,60	2,35	2,89	3,81	18	380	860
	468. 846	-	○	-	4,05	3,20	7,18	9,47	12,50	3,75	14,70	18,03	23,80	24,5	380	960
120°	468. 408	○	○	-	1,20	0,85	0,57	0,76	1,00	0,30	1,18	1,44	1,90	18	680	1540
	468. 488	○	○	-	1,50	1,00	0,92	1,21	1,60	0,48	1,88	2,31	3,05	18	680	1540
	468. 528	○	○	-	1,65	1,20	1,15	1,52	2,00	0,60	2,35	2,89	3,81	18	680	1540

B = bore diameter · E = narrowest free cross section

The folded page at the end of the catalogue will give you a survey on the various assembly possibilities. For complete assembly accessories, please refer to „Accessories“.

Example	Type	+	Material no.	=	Ordering no.
for ordering:	468. 644	+	5E	=	468. 644. 5E

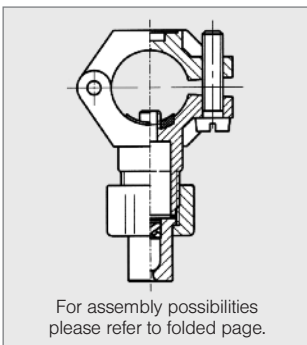

Conversion formula for the above series: $\dot{V}_2 = \dot{V}_1 * \left(\frac{p_2}{p_1}\right)^{0,4}$ (≤ 10 bar)



Tangential-flow full cone nozzles

Series 422



Tangentially arranged liquid supply. Without swirl inserts. Non-clogging. Stable spray angle. Uniform spray.

Applications:
Cleaning and washing process, cooling of gaseous fluids and solids, surface spraying, spraying onto mats in air washers, improving on chemical reactions, continuous casting, foam control.

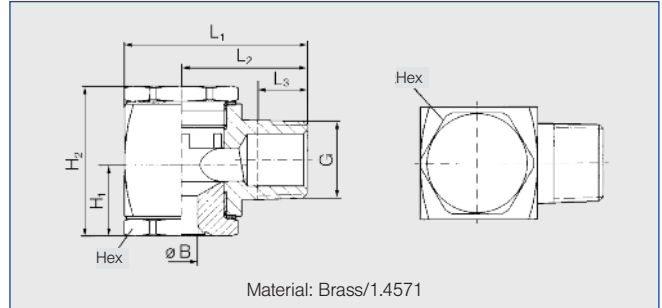

G	Dimensions [mm]						Weight Brass
	L ₁	L ₂	L ₃	H ₁	H ₂	Hex	
1/4 BSPT	28,0	20,0	10,0	8,0	20,5	12,0	43 g
3/8 BSPT	36,0	25,0	10,0	11,0	26,5	19,0	105 g
1/2 BSPT	48,5	33,5	13,0	20,0	38,5	27,0	250 g

Spray angle	Ordering no.						B Ø [mm]	E Ø [mm]	V̇ [l/min]							Spray diameter D at p=1-10 bar		
	Type	Mat.-no.		Code		p [bar]							Diagram					
		Brass	1.4571/316SS	1/4 BSPT	3/8 BSPT	1/2 BSPT			0,5	1,0	2,0	[US gal./min] at 40 psi	3,0	5,0	10,0	H = 200 mm	H = 500 mm	
60°	422.644	○	○	-	CE	-	3,00	3,00	2,00	2,83	4,00	1,24	4,90	6,32	8,94	225	510	
	90°	422.406	○	-	CC	-	-	1,50	1,45	0,50	0,71	1,00	0,31	1,22	1,58	2,24	380	860
		422.486	-	○	CC	-	-	1,90	1,80	0,80	1,13	1,60	0,50	1,96	2,53	3,58	380	860
		422.566	○	○	CC	-	-	2,30	2,20	1,25	1,77	2,50	0,78	3,06	3,95	5,59	380	860
		422.606	○	○	-	CE	-	2,60	2,50	1,57	2,23	3,15	0,98	3,86	4,98	7,04	380	860
		422.646	○	○	-	CE	-	3,00	2,90	2,00	2,83	4,00	1,24	4,90	6,32	8,94	390	960
		422.686	○	-	-	CE	-	3,30	3,20	2,50	3,54	5,00	1,55	6,12	7,91	11,18	390	960
		422.726	○	-	-	CE	-	3,70	3,60	3,15	4,45	6,30	1,95	7,72	9,96	14,09	390	960
		422.766	-	○	-	CE	-	4,15	4,10	4,00	5,66	8,00	2,48	9,80	12,65	17,89	390	960
		422.806	○	-	-	CE	-	4,65	4,60	5,00	7,07	10,00	3,10	12,25	15,81	22,36	390	960
422.846	○	○	-	CE	-	5,20	5,10	6,25	8,84	12,50	3,88	15,31	19,76	27,95	390	960		
422.886	○	-	-	CE	-	5,80	5,70	8,00	11,31	16,00	4,96	19,60	25,30	35,78	390	960		
422.966	-	○	-	-	CG	8,00	8,00	12,50	17,68	25,00	7,75	30,62	39,53	55,90	390	960		
120°	422.488	○	○	CC	-	-	1,90	1,80	0,80	1,13	1,60	0,50	1,96	2,53	3,58	680	1220	
	422.568	○	-	CC	-	-	2,30	2,20	1,25	1,77	2,50	0,78	3,06	3,95	5,59	680	1220	
	422.608	○	-	-	CE	-	2,60	2,50	1,57	2,23	3,15	0,98	3,86	4,98	7,04	680	1600	
	422.728	○	○	-	CE	-	3,70	3,60	3,15	4,45	6,30	1,95	7,72	9,96	14,09	680	1600	
	422.808	-	○	-	CE	-	4,65	4,60	5,00	7,07	10,00	3,10	12,25	15,81	22,36	680	1600	
	422.848	○	○	-	CE	-	5,20	5,10	6,25	8,84	12,50	3,88	15,31	19,76	27,95	680	1600	
	422.888	○	○	-	CE	-	5,80	5,70	8,00	11,31	16,00	4,96	19,60	25,30	35,78	680	1600	
	422.928	-	○	-	-	CG	7,30	7,30	10,00	14,14	20,00	6,20	24,49	31,62	44,72	680	1600	
	422.968	○	-	-	-	CG	8,00	8,00	12,50	17,68	25,00	7,75	30,62	39,53	55,90	680	1600	

B = bore diameter · E = narrowest free cross section

Plastic version see next page.

Example	Type	+	Material no.	+	Code	=	Ordering no.
for ordering:	422.644	+	30	+	CE	=	422.644.30.CE

The folded page at the end of the catalogue will give you a survey on the various assembly possibilities. For complete assembly accessories, please refer to „Accessories“.



Conversion formula for the above series: $\dot{V}_2 = \dot{V}_1 * \sqrt{\frac{p_2}{p_1}}$



Tangential-flow full cone nozzles

Plastic version

Series 422/423



Tangentially arranged liquid supply. Without swirl inserts. Non-clogging. Stable spray angle. Uniform spray.

Applications:

Cleaning and washing process, cooling of gaseous fluids and solids, surface spraying, spraying onto mats in air washers, improving on chemical reactions, foam control.

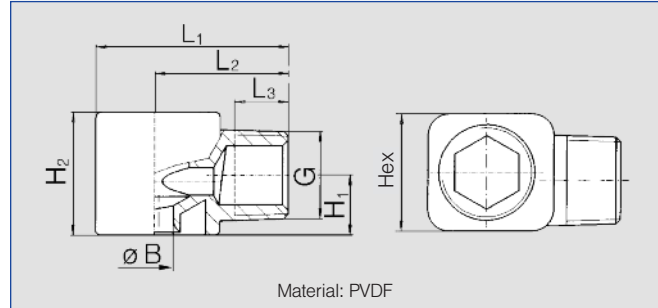

Material: PVDF

G	Dimensions [mm]						Weight PVDF
	L ₁	L ₂	L ₃	H ₁	H ₂	Hex	
1/4 BSPT	28,0	20,0	9,8	8,0	16,0	16,0	7 g
3/8 BSPT	36,0	25,0	10,1	11,2	23,0	22,0	16 g
1/2 BSPT	49,5	33,5	13,2	19,2	38,0	32,0	40 g
3/4 BSPT	58,5	38,5	18,5	24,5	50,0	41,0	50 g

Spray angle	Ordering no.						B Ø [mm]	E Ø [mm]	\dot{V} [l/min]							Spray diameter D at p=1-10 bar		
	Type	Mat.-no.	Code						p [bar]									
			PVDF	1/4 BSPT	3/8 BSPT	1/2 BSPT			3/4 BSPT	0,5	1,0	2,0	[US gal./min] at 40 psi	3,0	5,0			10,0
60°	422. 724	○	-	CE	-	-	3,60	3,60	3,15	4,45	6,30	1,95	7,72	9,96	14,09	225	510	
	90°	422. 406	○	CC	-	-	-	1,50	1,45	0,50	0,71	1,00	0,31	1,22	1,58	2,24	380	860
		422. 566	○	CC	-	-	-	2,30	2,20	1,25	1,77	2,50	0,78	3,06	3,95	5,59	380	860
		422. 606	○	-	CE	-	-	2,60	2,50	1,57	2,23	3,15	0,98	3,86	4,98	7,04	380	860
		422. 646	○	-	CE	-	-	3,00	2,90	2,00	2,83	4,00	1,24	4,90	6,32	8,94	390	960
		422. 726	○	-	CE	-	-	3,70	3,60	3,15	4,45	6,30	1,95	7,72	9,96	14,09	390	960
		422. 806	○	-	CE	-	-	4,65	4,60	5,00	7,07	10,00	3,10	12,25	15,81	22,36	390	960
		422. 846	○	-	CE	-	-	5,20	5,10	6,25	8,84	12,50	3,88	15,31	19,76	27,95	390	960
		422. 886	○	-	CE	-	-	5,80	5,70	8,00	11,31	16,00	4,96	19,60	25,30	35,78	390	960
		422. 926	○	-	-	CG	-	7,30	7,30	10,00	14,14	20,00	6,20	24,49	31,62	44,72	390	960
422. 966		○	-	-	CG	-	8,00	8,00	12,50	17,68	25,00	7,75	30,62	39,53	55,90	390	960	
423. 006	○	-	-	CG	-	8,70	8,70	15,75	22,27	31,50	9,77	38,58	49,81	70,44	390	960		
423. 126	○	-	-	-	CK	12,00	12,00	31,50	44,55	63,00	19,54	77,16	99,61	140,87	390	960		
120°	422. 408	○	CC	-	-	-	1,50	1,45	0,50	0,71	1,00	0,31	1,22	1,58	2,24	680	1220	
	422. 448	○	CC	-	-	-	1,65	1,60	0,62	0,88	1,25	0,39	1,53	1,98	2,80	680	1220	
	422. 488	○	CC	-	-	-	1,90	1,80	0,80	1,13	1,60	0,50	1,96	2,53	3,58	680	1220	
	422. 568	○	CC	-	-	-	2,30	2,20	1,25	1,77	2,50	0,78	3,06	3,95	5,59	680	1220	
	422. 728	○	-	CE	-	-	3,70	3,60	3,15	4,45	6,30	1,95	7,72	9,96	14,09	680	1600	
	422. 888	○	-	CE	-	-	5,80	5,70	8,00	11,31	16,00	4,96	19,60	25,30	35,78	680	1600	
	423. 008	○	-	-	CG	-	8,70	8,70	15,75	22,27	31,50	9,77	38,58	49,81	70,44	680	1600	
	423. 128	○	-	-	-	CK	12,70	12,30	31,50	44,55	63,00	19,54	77,16	99,61	140,87	680	1600	

B = bore diameter · E = narrowest free cross section

The folded page at the end of the catalogue will give you a survey on the various assembly possibilities. For complete assembly accessories, please refer to „Accessories“.

Example for ordering	Type	+	Material no.	+	Code	=	Ordering no.
	422. 724	+	5E	+	CC	=	422. 724. 5E. CC

Conversion formula for the above series: $\dot{V}_2 = \dot{V}_1 \cdot \sqrt{\frac{p_2}{p_1}}$





Tangential-flow full cone nozzles

Bayonet quick-release system

Series 422



Quick and safe assembly, without tool. Space-saving installation. Non-clogging and maintenance-free. High resistance to temperatures and chemicals.

Applications:
Cleaning problems, cooling process, foam control.

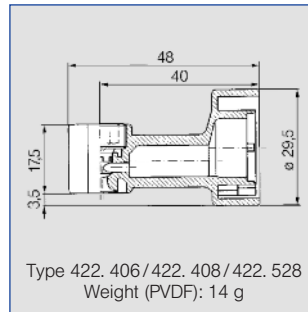
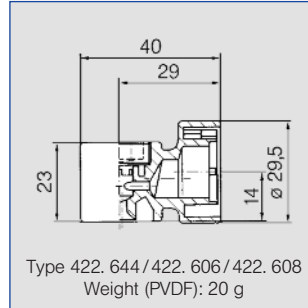

Spray angle	Ordering no.				B \varnothing [mm]	E \varnothing [mm]	\dot{V} [l/min]						Spray diameter D at p=1-10 bar		
	Type	Mat.-no.		Code			p [bar]						 H = 200 mm H = 500 mm		
		5E	53				Bayonet quick-release		0,5	1,0	2,0	[US gal./min] at 40 psi			3,0
		PVDF	PP												
60°	422. 644	-	○	KB	2,90	2,90	2,00	2,83	4,00	1,24	4,90	6,32	8,94	225	510
	422. 406	○	-	KB	1,50	1,45	0,50	0,71	1,00	0,31	1,22	1,58	2,24	380	860
90°	422. 606	○	-	KB	2,60	2,50	1,57	2,23	3,15	0,98	3,86	4,98	7,04	380	860
	422. 408	○	-	KB	1,50	1,45	0,50	0,71	1,00	0,31	1,22	1,58	2,24	680	1220
120°	422. 528	○	-	KB	2,10	2,00	1,00	1,41	2,00	0,62	2,45	3,16	4,47	680	1220
	422. 608	○	-	KB	2,60	2,50	1,57	2,23	3,15	0,98	3,86	4,98	7,04	680	1600

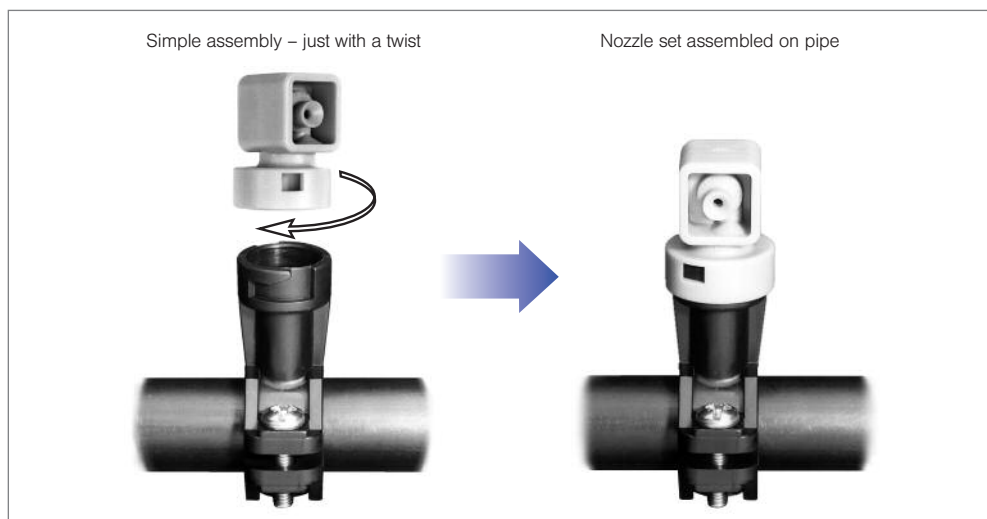

B = bore diameter ·
E = narrowest free cross section

The folded page at the end of the catalogue will give you a survey on the various assembly possibilities. For complete assembly accessories, please refer to „Accessories“.



Cluster head nozzles

Series 502 / 503



Fine full cone atomization with the aid of several hollow cones spraying into one another.

Applications:

Cooling of gaseous and solid material, desuperheating, chlorine precipitation, absorption as well as for improvement of chemical reaction by enlarging the contact area.

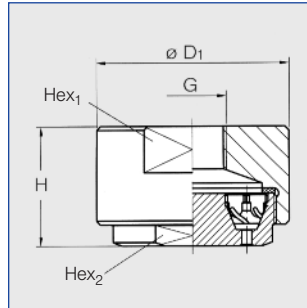

	Dimensions	
	1/2"	3/4"
Hex ₁	46	65
Hex ₂	38	55
H	25	46
D ₁	50	75
Weight (Brass)	250 g	870 g

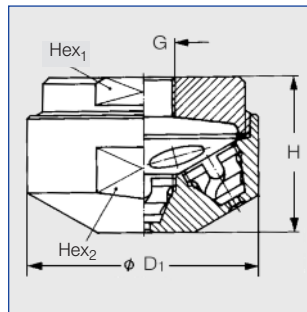
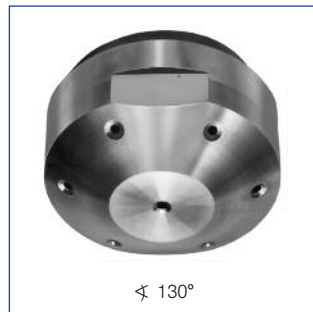

	Dimensions	
	1/2"	3/4"
Hex ₁	27	50
Hex ₂	36	55
H	28	53
D ₁	40	60
Weight (Brass)	150 g	410 g

Spray angle	Ordering no.		G	B ∅ [mm]	E ∅ [mm]	V̇ [l/min]						Spray diameter D at p = 2 bar	
	Type	Mat.-no.				p [bar]						H = 1000 mm	H = 2000 mm
						0,5	1,0	2,0	[US gal./min] at 40 psi	5,0	10,0		
70°	502. 445	-	1/2"	1,00	0,50	-	-	1,25	0,39	1,98	2,80	400	400
	502. 985	○	3/4"	3,50	2,00	14,00	19,80	28,00	8,68	44,30	62,60	1200	1500
	503. 065	○	3/4"	5,00	2,00	22,10	31,80	45,00	13,96	71,10	100,60	1200	1800
130°	502. 448	○	1/2"	1,00	0,50	-	-	1,25	0,39	1,98	2,80	500	500
	502. 548	○	1/2"	1,80	0,50	-	-	1,58	2,24	0,69	3,54	5,01	700
	502. 748	○	3/4"	2,00	2,00	3,50	5,00	7,10	2,20	11,20	15,90	1100	1200
	502. 798	○	3/4"	2,50	2,00	4,60	6,70	9,50	2,95	15,00	21,20	1200	1300
	502. 838	○	3/4"	3,00	2,00	4,60	8,30	11,80	3,66	18,70	26,40	1400	1600
	502. 908	○	3/4"	4,00	2,00	8,80	12,70	18,00	5,58	28,40	40,20	1500	1800
	503. 028	○	3/4"	4,00	2,00	17,70	25,10	35,50	11,01	56,10	79,40	1600	1800
503. 118	○	3/4"	6,00	2,00	30,00	42,00	60,00	18,61	95,00	134,00	2000	3000	

B = bore diameter · E = narrowest free cross section

The folded page at the end of the catalogue will give you a survey on the various assembly possibilities. For complete assembly accessories, please refer to „Accessories“.

Example	Type	+	Material no.	=	Ordering no.
for ordering:	502. 445	+	30	=	502. 445. 30

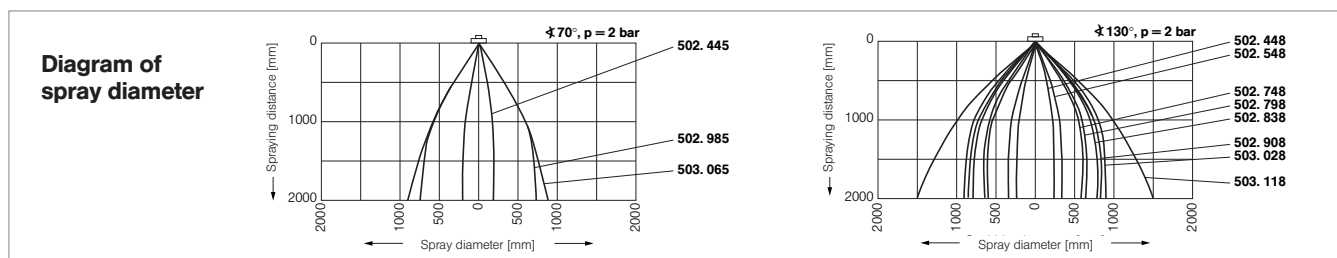

Conversion formula for the above series: $\dot{V}_2 = \dot{V}_1 \cdot \sqrt{\frac{p_2}{p_1}}$





Deflector-plate nozzle

Series 525

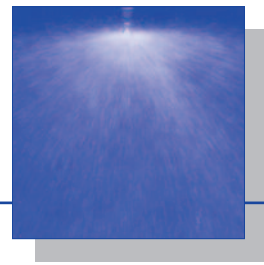

Full cone spray. Non clogging nozzle without swirl insert.

Applications:

Fire fighting and broadcast spraying, wide area spray.

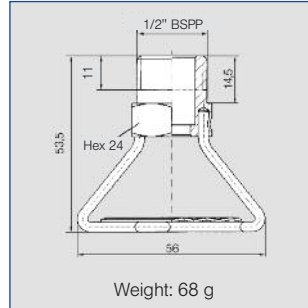

Weight: 68 g

Spray angle	Ordering no.		B Ø mm	\dot{V} [l/min]						Spray diameter D at p=3 bar ca.	
	Type	Mat. no.		p [bar]						 H = 1 m H = 3 m	
				0,5	1,0	[US gal./ min] at 40 psi	3,0	5,0	10,0		
180°	524. 809	○ ○	4,00	5,00	7,10	3,10	12,20	15,80	22,40	5,60 m	6,40 m
	525. 049*	○ ○	8,00	20,00	28,30	12,41	49,00	63,20	89,40	10,00 m	13,20 m
	525. 109*	○ -	9,30	28,00	40,00	17,37	69,00	89,00	125,00	10,20 m	13,40 m
	525. 169*	○ -	10,90	40,00	57,00	24,81	98,00	126,00	179,00	10,60 m	13,60 m
	525. 229	○ -	12,20	56,00	79,00	34,73	137,00	177,00	250,00	6,80 m	10,40 m
	525. 269	○ ○	12,30	70,00	99,00	43,42	171,00	221,00	313,00	5,20 m	10,20 m

B = bore diameter

Example:	Type	+	Material no.	=	Ordering no.
for ordering	524. 809	+	30	=	524. 089. 30

***Lechler deflector-plate nozzles are VDS approved. VDS registration number for all 3 nozzle types is: A 4870876**



For information on further fire fighting nozzles please refer to our brochure „Lechler nozzles for fire fighting“. Please ask for this brochure, using the telefax form at the end of the catalogue.